

**Generator set
Sound-proof type**

T312XS

SPECIFICATIONS

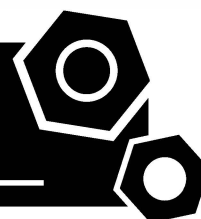

1 Standards & Conditions

Design Standards

The designs and the productions are in conformity with:

- Conformance Européenne (CE)
- ISO8528-5:2005
- GB/T2820.5-2009

Environmental Operating Conditions

- Installation place: Outdoors or indoors (well ventilated).
- Ambient temperature: -25°C to 50°C. The coolant heater is needed when the temperature is below 5°C
- Humidity: Less than 80%.
- Altitude: Below one thousand (1000) meters.

Factory Inspection

- Inspection items.
- Protection devices working test.
- Starting ability in normal temperature.
- 50% rated power load moment capability.
- Voltage deviation and speed variation: 0%, 25%, 50%, 75%, 100%, 110% Load.

Painting Process

- Painting process specifications and colors are based on the manufacturer's standard.
- The customer could also choose the color which the manufacturer offers.

2 General Features

- Powerlink engine QSE12-G2
- Close coupled to LSA alternator LSA47.2VS1
- Microprocessor control module XC762
- Main circuit breaker: 500A
- Speed governor: ECU
- Excitation System: Self excited
- A.V.R.Model: R250
- Key switch
- Emergency stop switch
- ATS (automatic transfer switch) receptacle
- 2x12V/120AH sealed for life maintenance free battery

- Lockable battery isolator switch
- Powder coated canopy
- 50°C radiator
- Oil pump on the engine
- Steel base frame with forkslots
- Vibration isolators between the engine/alternator and base frame
- Dry type air filter
- Base fuel tank for 12 hours running
- Drain points for fuel tank
- Operation Manual / Specifications

3 Equipment Specification

General technical data

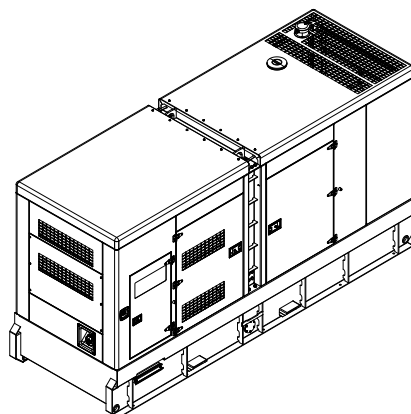

Model..... T312XS
 Structure type R
 Tank capacity.....800L
 Dry weight.....4560kg
 Sound pressure level @7m 73.5dB(A)
 Emissions complianceCHINA STAGE III
 Dimensions L×W×H.....4242x1464x2312mm
 Standby Power344kVA/275kW
 Prime Power..... 313kVA/250kW

Voltage	380V	400V	415V	440V	
Ampere	475.6A	451.8A	435.5A	410.7A	
Genset Fuel Consumption					
Frequency/Load	25%	50%	75%	100%	110%
50Hz (L/h)	N/A	33.1	48.2	65.9	73.6

Dck Yf 'GrghYa

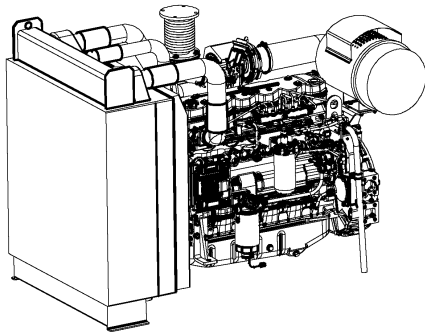

Engine Manufacturer/Brand	Powerlink
Engine Model	QSE12-G2
Dimensions L×W×H.....	1787×918×1294mm
Dry Weigh (approx.)	1165kg
Number of Cylinders.....	6
Bore.....	128mm
Stroke	153mm
Displacement.....	11.8L
Compression Ratio	17
Type of Injection.....	High pressure common rail
Intake System.....	Turbocharged
Intake Resistance	≤8kPa
Cooling System	Water cooled
Fan	Pusher
Battery Voltage	24V
Type of Fuel.....	RF75-T-96 / DIN EN590 / BS2869 class A2
Type of Oil	API-CG4/ CH4
Oil Capacity	41.0L
Type of Coolant	Glycol mixture
Coolant Capacity	23.2L
Back Pressure	≤10kPa
Standby Power	308kW
Prime Power	280kW
Fuel Consumption(100%load)	65.9L/h

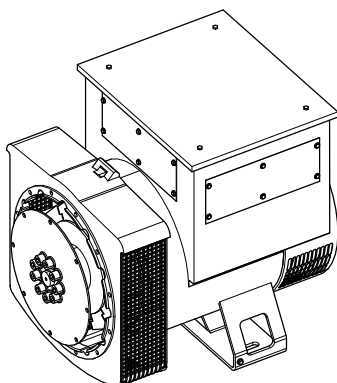

Alternator Manufacturer/Brand	Leroy Somer
Alternator Model	LSA47.2VS1
Exciter.....	Brushless
Cooling Fan	Cast alloy aluminum
Windings.....	100% copper
Insulation Class	H
Winding Pitch.....	2/3
Terminals	12
Drip Proof	IP23
Altitude.....	≤1000m
Overspeed	2250 rpm
Air Flow.....	0.216m³/s(50HZ),0.281m³/s(60HZ)
Voltage Regulation	±1.0%
Total harmonic TGH / THCat no load < 1.5 % - on load < 5%	
Telephone Interference.....	THF<2%;TIF<50

XC762 Control System

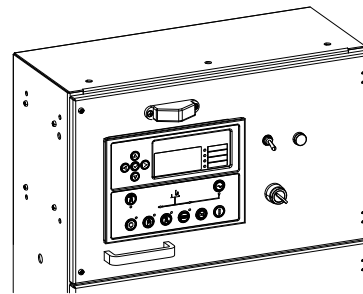

XC762 is an advanced control module based on micro-processor, containing all necessary functions for protection of the genset and the breaker control. It can monitor the mains supply, and automatically start the engine when the mains is abnormal. Accurately measure various operational parameters and display all values and alarms information on the LCD. In addition, the control module can automatically shut down the engine and indicate the engine failure.

- Microprocessor control, with high stability and credibility
- Monitoring and measuring operational parameters of the mains supply and genset
- Indicating operation status, fault conditions, all parameters and alarms
- Multiple protections; multiple parameters display, like pressure, temp. etc.
- Manual, automatic and remote work mode selectable
- Real time clock for time and date display, overall runtime display, 250 log entries
- Overall power output display
- Integral speed/frequency detecting, telling status of start, rated operation, overspeed etc.
- Communication with PC via RS485 OR RS232 interface, using MODBUS protocol

4 Overall Dimensions

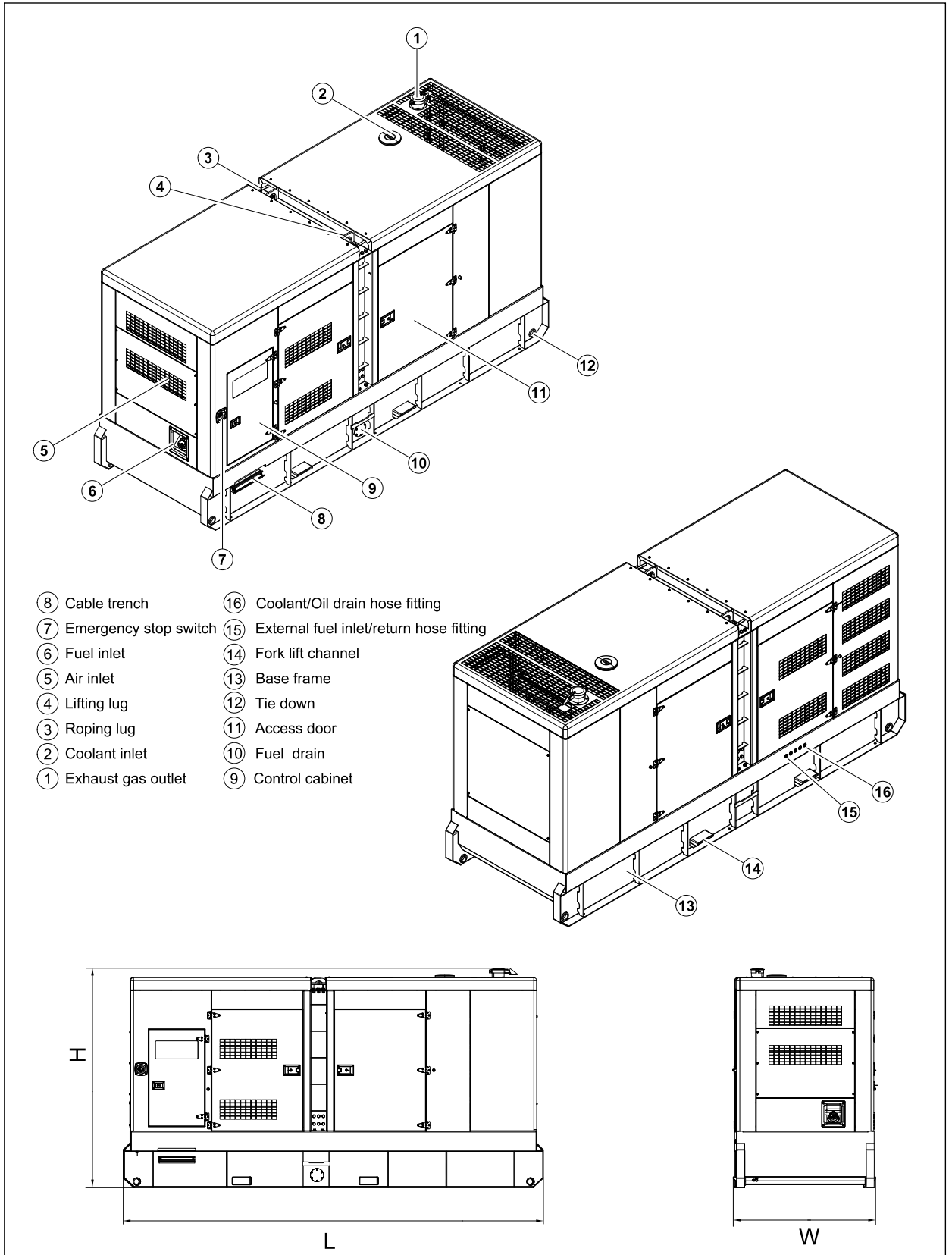

5 Control System

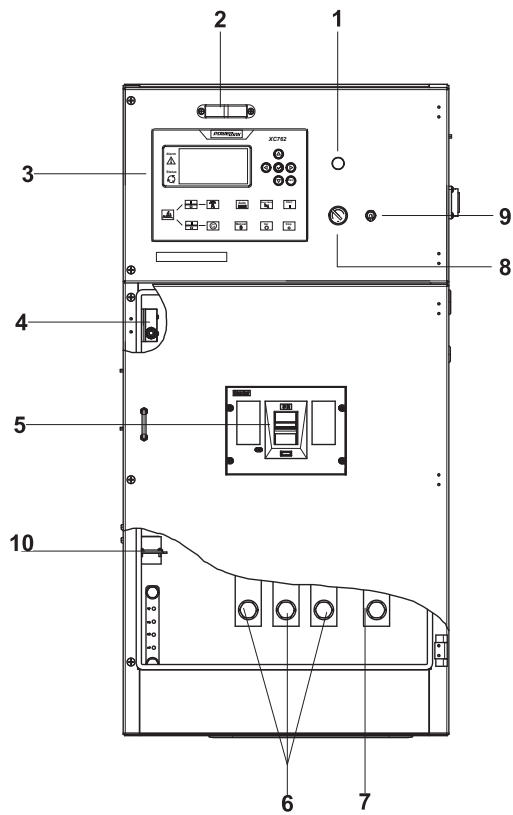

Control & field wiring cabinet

Ref.	Description
1	Charge indicator
2	Control cabinet lamp
3	XC762 control module
4	Limit switch
5	Main circuit breaker
6	Live wire terminals
7	Neutral wire terminal
8	Key switch
9	Control cabinet lamp switch
10	Mains input/remote/AMF communication connector

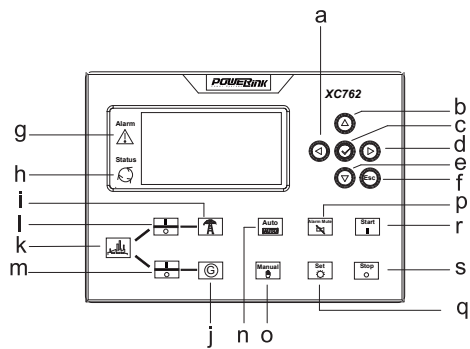

Control module

a	Button (next page)
b	Button (increase value / previous item)
c	Button (accept)
d	Button (previous page)
e	Button (decrease value / next item)
f	Button (ESC)
g	Indicator (alarm)
h	Indicator (running)
i	Indicator (mains available)
j	Indicator (genset available)
k	Indicator (mains / genset ON)
l	Button (breaker ON / OFF)
m	Button (breaker ON / OFF)
n	Button (Auto mode)
o	Button (Manual mode)
p	Button (reset alarm)
q	Button (set parameters)
r	Button (start)
s	Button (stop)

100030533-A-E

11.2019

<http://www.powerlinkworld.com>

*Specification may change without prior notice. For more info.,
contact Power Link or your local distributors please.*